



# SUBMITTAL : ECO-200SW30 200 Gallon & 30kw Swing Tank



Job Name	Location		
Purchaser	Engineer		
Submitted to	Reference <input type="checkbox"/>	Approval <input type="checkbox"/>	Construction <input type="checkbox"/>
Unit Designation	Schedule #		

Specifications	GS4-45HPC & -D
<b>Performance</b>	
Capacity per Heat Pump	4.5kw or 15,400 Btu/h
Recovery per HP @ 90°F Rise	20.6 Gallons per Hour
<b>Storage Tank</b>	
<b>ECO-200SW30</b>	
Tank Volume Actual/Nominal	200 Gallons
Pressure Relief Valve (Psig & °F)	150 Psig
Temperature Sensor	Immersion Thermostat
Installed Tank Weight (lbs)	550lbs
Shipping Tank Weight (lbs)	742lbs
Anodes	3 x Magnesium
<b>Tank Connection Sizes</b>	
Recirc/HP Manifold Inlet	1 1/2" NPT
Hot Water Outlet	1 1/2" NPT
<b>Electric Elements</b>	
Number of Elements	2
Element Output	30kw
Number of Element Contactors	2
<b>Amperage Draw -Various Power Supplies</b>	
208V-1Ph	144.0A
240V-1Ph	125.0A
208V-3Ph	83.0A
240V-3Ph	72.0A
<b>Approvals</b>	
Tank	ASME
	ETL & ETLc
<b>Warranty</b>	
Tank	5 Years

### Construction

The tank shall be manufactured from carbon steel with an Ultranium glass lining is applied to the inside surface of the steel tank and fired to 1600°F. The Tank shall be constructed in accordance with the ASME code

### Insulation

High-density closed cell foam insulation shall be used to meet the ASHRAE 90.1b current standard for minimizing heat loss. This requirement, allowing a maximum 4 watts per square foot of tank surface energy loss

### Water Connections

Connections to the Recirculation loop and Hot Water from the GS4 Heat Pump Manifold shall be 1 1/2"

### Electric Elements

Low Watt Density Incoloy Elements shall be used to ensure that the elements resist the effects of high operating temperatures, hard water acids, corrosion and thermal shock in addition to water voids

### Controls

Magnetic Contactors with Immersion Thermostats. 120 volt control circuit with built in transformer. Elements are thermostatically controlled in 54kw (Max) increments  
Internal fusing shall have the electric element and circuit fused in 48A increments to ensure electrical protection  
Cartridge type fuses shall be rated at 200,000 Ampere interrupting capacity  
Terminal Block Connections shall be provided to ensure field wiring  
Building Management Interface contacts shall be provided to ensure remote control of the Swing Tank

### Pressure and Temperature Relief

Tank shall be supplied with a field installed, ASME approved Pressure relief valve  
Valve Setting shall be at 150 Psig  
Relief Valve shall be piped to a suitable location in case of discharge



# SUBMITTAL : ECO-200SW30 200 Gallon & 30kw Swing Tank



Job Name	Location		
Purchaser	Engineer		
Submitted to	Reference <input type="checkbox"/>	Approval <input type="checkbox"/>	Construction <input type="checkbox"/>
Unit Designation	Schedule #		

## Storage Tank Dimensions

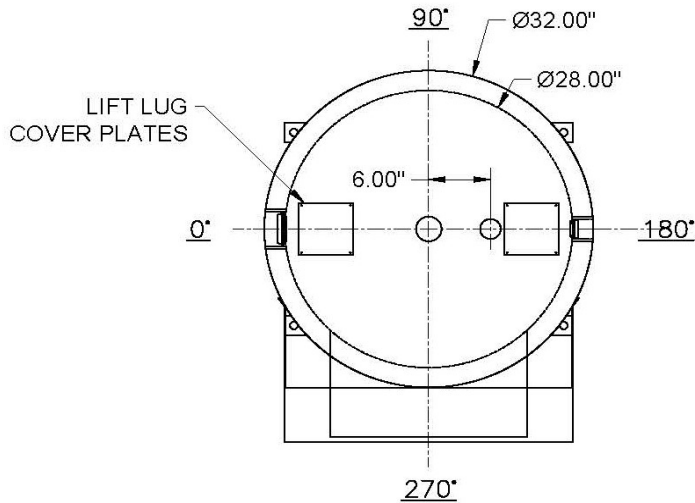

CUSTOMER:

CONSTRUCTION:  
 MATERIAL: CARBON STEEL  
 INTERIOR LINING: ULTONIUM  
 EXTERIOR: INSULATED W/ STEEL JACKET  
 SACRIFICIAL ANODES: MAGNESIUM  
 M.A.W.P.: 150 PSI  
 MAX. OPERATING TEMP.: 180°F

OPTIONAL ADDERS:  
 A - BMS CONTACTS

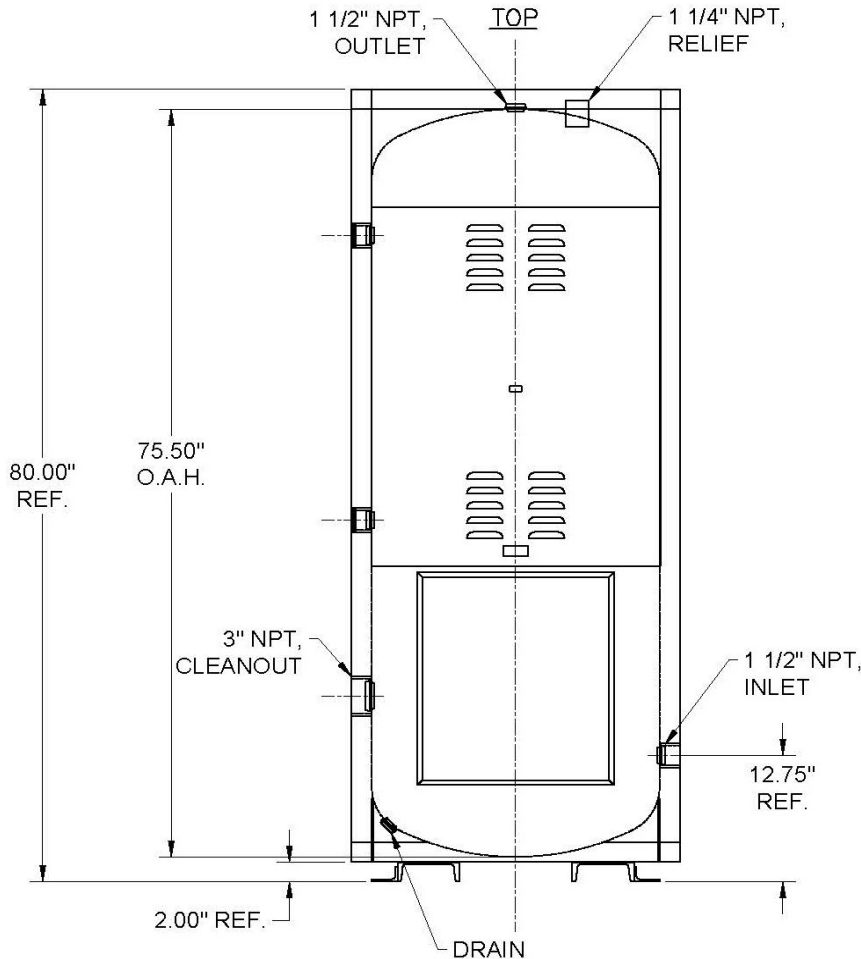

Eco2 Systems LLC

PO Box 1358, Walled Lake MI 48390, Tel : 1-844 SAND CO2 (1-844 726 3262)

[www.eco2waterheater.com](http://www.eco2waterheater.com)

Due to Eco2 Systems LLC's policy of on-going product development specifications are subject to change without notice

SUB-ECO2-200SW30-062023

© Eco2 Systems LLC 2023

